

**VACUUM FLUORESCENT DISPLAY
MODULE
SPECIFICATION**

MODEL: GU256X64F-9900

SPECIFICATION NO. : DS-1529-0000-00
DATA OF ISSUE : July 03, 2008
REVISION : November 05, 2008

PUBLISHED BY
NORITAKE ITRON CORP. / JAPAN

This specification is subject to change without prior notice.

This product complies with RoHS Directive 2002/95/EC

1. General Description

1.1 Scope

This specification covers the requirements of vacuum fluorescent graphic display module, Model:GU256X64F-9900.

Applied reliability spec: TT-99-3102
Applied production spec: TT-98-3413

1.2 Construction

The module consists of a graphic BD-VFD which does have the dot configuration of 64X256, a refresh RAM, a character generator, a DC/DC converter, a display controller and all necessary control logics.

The module can display graphic patterns and /or characters in a screen of the VFD.

2. Absolute Maximum Ratings

Parameter	Symbol	Min.	Typ.	Max.	Unit
Power Supply Voltage	V _{CC}	0	-	5.5	V _{DC}
Logic Input Voltage	V _{IN}	0	-	V _{CC} +0.3	V _{DC}

3. Electrical ratings

Parameter	Symbol	Min.	Typ.	Max.	Unit
Power Supply Voltage	V _{CC}	4.75	5.0	5.25	V _{DC}

All driving voltage for the VFD is converted from the DC/DC converter on board.

4. Electrical Characteristics

Measuring Conditions : TA (Ambient temperature) = 25degrees, V_{CC} =5.0V_{DC}

Parameter	Symbol	Min.	Typ.	Max.	Unit	Condition	Note	
Logic Input Voltage	"H"	V _{IH}	3.5	-	V _{CC}	V _{DC}	-	-
	"L"	V _{IL}	-	-	1.5	V _{DC}	-	-
Logic Output Voltage	"H"	V _{OH}	4.0	-	-	V _{DC}	I _{OH} =-2mA	-
	"L"	V _{OL}	-	-	0.4	V _{DC}	I _{OL} =4mA	-
Power Supply Current 1	ICC1	-	1.2	1.6	A		(1)	
Power Supply Current 2	ICC2	-	0.9	1.2	A		(2)	

Note

(1),(2) ICC1 shows the current at all dots in the screen are lighted and ICC2 at all dots off. At power on rush, more than 2times current of above table should be expected. Provide the quick rise type power supply (<100msec.).

After power-on, data and commands cannot be received for 80msec. Please wait 80msec minimum before inputting data or commands.

5. Optical Specifications

Number of dots	: 16384(256x64)
PCB Size	: 230.0 mm X 78.0 mm (X × Y)
Display area	: 166.25 mm X 41.45 mm (X × Y)
Dot size	: 0.5 mm X 0.5 mm (X × Y)
Dot pitch	: 0.65 mm X 0.65 mm (X × Y)
Luminance	: 350cd/m ² Min (500cd/m ² Typ.)
Color of illumination	: Green(Blue Green)
Weight	: 307(g)

6. Environmental Specifications

Operating temperature	: -40 to +85degrees
Storage temperature	: -40 to +85degrees
Storage humidity	: 20 to 80 % R.H(Non Condensation)
Vibration	: 10-55-10Hz, all amplitude 1mm, 30Min., X-Y-Z(Non operating)
Shock	: 539m/s ² (55G) 10mS(Non operating)

7. Functions Of Data Lines

Data Line	Function
D0~D7	Data Bus(Input / Output)
$\overline{\text{WR}}$	Write Signal(Input)
$\overline{\text{RD}}$	Read Signal (Input)
$\overline{\text{CS}}$	Chip Select Signal(Input)
$\overline{\text{C/D}}$	Command / Data Select Signal(Input) C/ $\overline{\text{D}}$ = "1" ... Command C/ $\overline{\text{D}}$ = "0" ... Data
FRP	Frame Signal(Output) (1 output pulse per 1 display frame)
$\overline{\text{BL}}$	Display Blanking Signal(Input)
Vcc	Input Voltage
GND	Ground

8. Construction and Major Functions

The module consists of 1 PC boards, control logics and DC/DC converter.

The display memory (RAM) has the capacity of 8k bytes and it can be memorized 4 screen pages at graphic mode and 8 screen pages at character mode(see para.11).

The module can display graphic patterns and /or characters in a screen of the VFD.

The display screens can be alternative as the screen #1 for graphic only and the screen #2 for character and graphic. Therefore, 4 different display combinations are available as follows.

- Graphic display only (use the screen #1 or #2)
- Character display only (use the screen #2)
- Merge 2 graphic displays such as OR/EX-OR/AND (use the screen #1 and #2)
- Graphic(use the screen #1) and Character(use the screen #2) displays such as OR/EX-OR/AND

The display pattern data can be written/read to/from the graphic screen and the display character code can be written/read to/from the character screen using data bus.

A character consists of 6 x 8 dots.

Since display start address can be set independently at both the screen #1 and #2, scrolling or page rolling might be also available independently.

Within the graphic screen, left and right scroll by 1 line (1 dot) unit is doable and the character screen can be able the upper and lower scroll by 1 column(8dots)unit.

8.1 Block Diagram

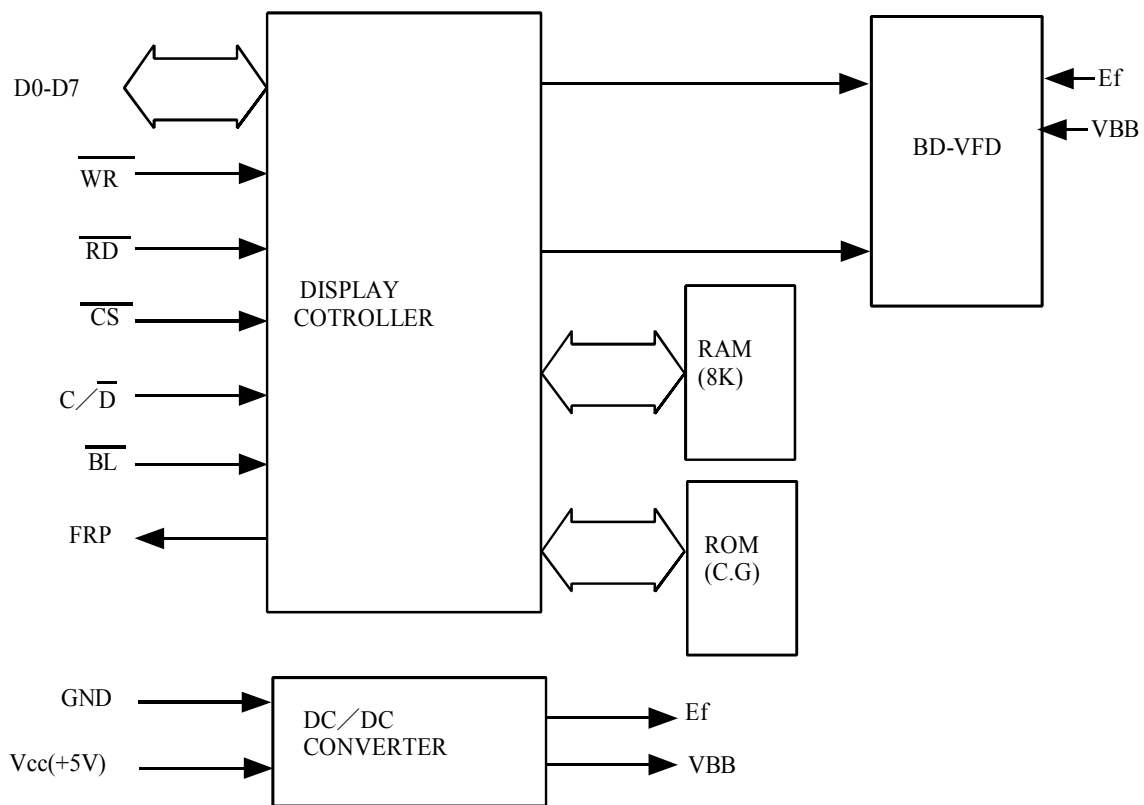

8.2 The Relationship of Display Memory and Command
 (XXH show the commands which will be described hereafter)

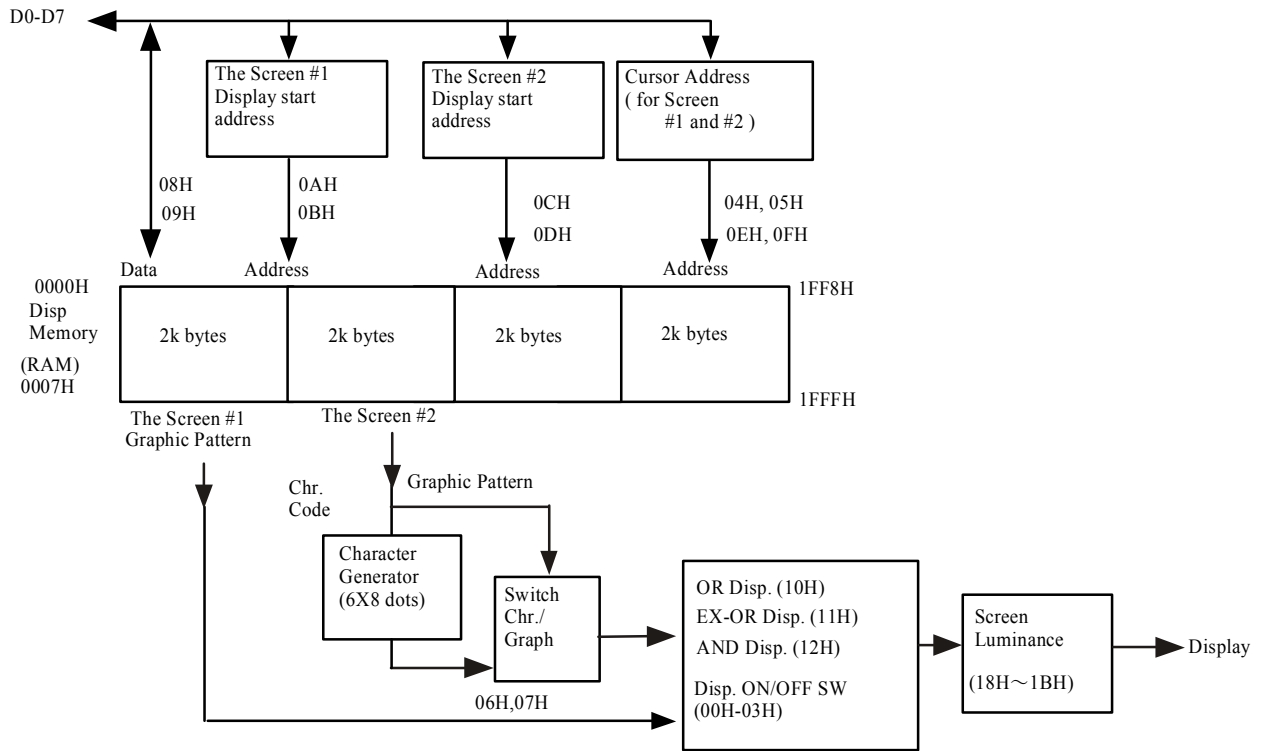

9.Commands

Command Table : Following table shows all commands and brief description of functions.

Command(C/D="1")					Setting Data(C/D="0")								Function	
D4	D3	D2	D1	D0	D7	D6	D5	D4	D3	D2	D1	D0		
0	0	0	0	0					—					Both Screen #1 & #2 are OFF
0	0	0	0	1					—					Only Screen #1 is ON
0	0	0	1	0					—					Only Screen #2 is ON
0	0	0	1	1					—					Both #1 & #2 are ON
0	0	1	0	0					—					Cursor increments automatically
0	0	1	0	1					—					Cursor holds
0	0	1	1	0					—					Screen #2 sets to "Character" disp.
0	0	1	1	1					—					Screen #2 sets to "Graphic" disp.
0	1	0	0	0	X	X	X	X	X	X	X	X	X	Data write mode.
0	1	0	0	1	X	X	X	X	X	X	X	X	X	Data read mode.
0	1	0	1	0	A7	A6	A5	A4	A3	A2	A1	A0		Lower byte of disp. start adrs. of #1.
0	1	0	1	1	X	X	X	A12	A11	A10	A9	A8		Upper byte of disp. start adrs. of #1.
0	1	1	0	0	A7	A6	A5	A4	A3	A2	A1	A0		Lower byte of disp. start adrs. of #2.
0	1	1	0	1	X	X	X	A12	A11	A10	A9	A8		Upper byte of disp. start adrs. of #2.
0	1	1	1	0	A7	A6	A5	A4	A3	A2	A1	A0		Set lower byte of cursor adrs. of #1 & #2.
0	1	1	1	1	X	X	X	A12	A11	A10	A9	A8		Set upper byte of cursor adrs. of #1 & #2.
1	0	0	0	0					—					Select screens merge mode. OR #1 & #2.
1	0	0	0	1					—					Select screens merge mode. Ex-OR #1 & #2.
1	0	0	1	0					—					Select screens merge mode. AND #1 & #2.
1	0	1	0	0					—					Set all display ON.
1	0	1	0	1					—					Set all display OFF.
1	1	0	0	0					—					Set brightness 100%
1	1	0	0	1					—					Set brightness 87.5%
1	1	0	1	0					—					Set brightness 75%
1	1	0	1	1					—					Set brightness 62.5%

The term "Cursor" means the writing or reading position.

Note 1/0: One bit data. X: Don't care

CAUTION : When the command not indicated by the above table is set, display module may cause operation trouble.

9.1 Screen Control

9.1.1 Screen ON/OFF Control

Command(C/D="1")					Function	Default Selection
D4	D3	D2	D1	D0		
0	0	0	0	0	Both Screen #1 and #2 are turned OFF.	X
0	0	0	0	1	Screen #1 is turned ON, Screen#2 is turned OFF.	
0	0	0	1	0	Screen #1 is turned OFF, Screen#2 is turned ON.	
0	0	0	1	1	Both screen #1 and #2 are turned ON.	

The latest command is valid from above table. At power on, Screen#1 and #2 are set to OFF. Therefore appropriate ON command should be written after writing of pattern data or character codes. When uses screen#2 as graphic display, command 07Hex should be sent before screen ON command.

9.1.2 OR/EX-OR/AND Display(Screen Merge)

Command(C/D="1")					Function	Default Selection
D4	D3	D2	D1	D0		
1	0	0	0	0	OR display of Screen #1 & #2	X
1	0	0	0	1	EX-OR display of Screen #1 & #2	
1	0	0	1	0	AND display of Screen #1 & #2	

The latest command is valid from above table.

These commands are only effective, when both screen#1 and #2 are turned on(command 03Hex).

If only one screen is selected, that screen is displayed without merge.

9.2 Display ON/OFF control

Command(C/D="1")					Function	Default Selection
D4	D3	D2	D1	D0		
1	0	1	0	0	Display is turned ON	X
1	0	1	0	1	Display is turned OFF	

When display is turned off, power converter also inhibited and reduce a power consumption.

9.3 Automatic Increment/ Hold of Cursor address

Command(C/D="1")					Function	Default Selection
D4	D3	D2	D1	D0		
0	0	1	0	0	Cursor is automatically incremented.	X
0	0	1	0	1	Cursor is not automatically incremented.(Hold)	

The cursor address which will be executed after Data Write or Data Read can be set to automatic INCREMENT or HOLD by above commands.

The cursor address will be incremented one address count on the address map covering all RAM area.

9.4 Character /Graphic Display

Command(C/D="1")					Function	Default Selection
D4	D3	D2	D1	D0		
0	0	1	1	0	Screen #2 is selected to Character Display	X
0	0	1	1	1	Screen #2 is selected to Graphic Display	

As described in para.9, the screen #1 is available graphic display only and where will be displayed bit pattern as is written from external system.

The screen #2, however, is selectable to graphic or character display.

Within the graphic display in the screen #2, the bit pattern will be displayed like as the screen #1.

When selects the character display in the screen #2, the character which is corresponded to the character code will be displayed. A character consists of 6x8 dots.

The character set is shown in the table(CFX001).

Since there are no control codes in the table, the writing position should be designated by the Cursor Setting Commands (0EH, 0FH) from external system.

		D7	D6	D5	D4																						
		0	0	1	1	0	0	0	0	1	1	1	1	1	1	1	1	1	1	1	1	1	1	1	1	1	
		0	0	1	1	0	0	1	1	0	0	1	1	0	0	1	1	0	0	1	1	0	0	1	1	0	0
		0	1	0	1	0	1	0	1	0	1	0	1	0	1	0	1	0	1	0	1	0	1	0	1	0	1
3210	DDDD	0	1	2	3	4	5	6	7	8	9	A	B	C	D	E	F										
0000	0					0	0	P	`	P	_	+	A	ó	á	á	á	=	X								
0001	1					!	1	A	Q	a	a	_	+	A	ó	á	á	á	á	á	á	á	á	á	á	á	á
0010	2					"	2	B	R	b	r	_	+	A	ó	á	á	á	á	á	á	á	á	á	á	á	á
0011	3					#	3	C	S	c	s	_	+	A	ó	á	á	á	á	á	á	á	á	á	á	á	á
0100	4					\$	4	D	T	d	t	_	+	A	ó	á	á	á	á	á	á	á	á	á	á	á	á
0101	5					%	5	E	U	e	u	_	+	A	ó	á	á	á	á	á	á	á	á	á	á	á	á
0110	6					&	6	F	V	f	v	_	+	A	ó	á	á	á	á	á	á	á	á	á	á	á	á
0111	7					'	7	G	W	w	w	_	+	A	ó	á	á	á	á	á	á	á	á	á	á	á	á
1000	8					(8	H	X	h	x	_	+	A	ó	á	á	á	á	á	á	á	á	á	á	á	á
1001	9)	9	I	Y	i	y	_	+	A	ó	á	á	á	á	á	á	á	á	á	á	á	á
1010	A					*	:	J	Z	j	z	_	+	A	ó	á	á	á	á	á	á	á	á	á	á	á	á
1011	B					+	:	K	L	k	l	_	+	A	ó	á	á	á	á	á	á	á	á	á	á	á	á
1100	C					,	<	L	\	l	!	_	+	A	ó	á	á	á	á	á	á	á	á	á	á	á	á
1101	D					-	=	M	I	m)	_	+	A	ó	á	á	á	á	á	á	á	á	á	á	á	á
1110	E					.	>	N	^	n	~	_	+	A	ó	á	á	á	á	á	á	á	á	á	á	á	á
1111	F					/	?	O	_	o		_	+	A	ó	á	á	á	á	á	á	á	á	á	á	á	á

CFX001 (G68001)

9.5 Data Write / Data Read

Command(C/D= $\bar{1}$)					Function
D4	D3	D2	D1	D0	
0	1	0	0	0	Set Data (pattern or character) Write mode.
0	1	0	0	1	Set Data (pattern or character) Read mode.

After cursor setting command, above Data Write or Data Read command is given.

The one byte data shall be written or read sequentially.

The cursor address can be incremented automatically by one address after write or read data with 04Hex command.

If 05Hex command is given, cursor stay same address even after write or read data operation.

CAUTION !: Within the data read mode, first byte (right after " DATA READ COMMAND") is invalid. The correct data will be read from the 2nd byte.

It is necessary a dummy read right after the "DATA READ COMMAND".

The correct data will be read from the 2nd byte.

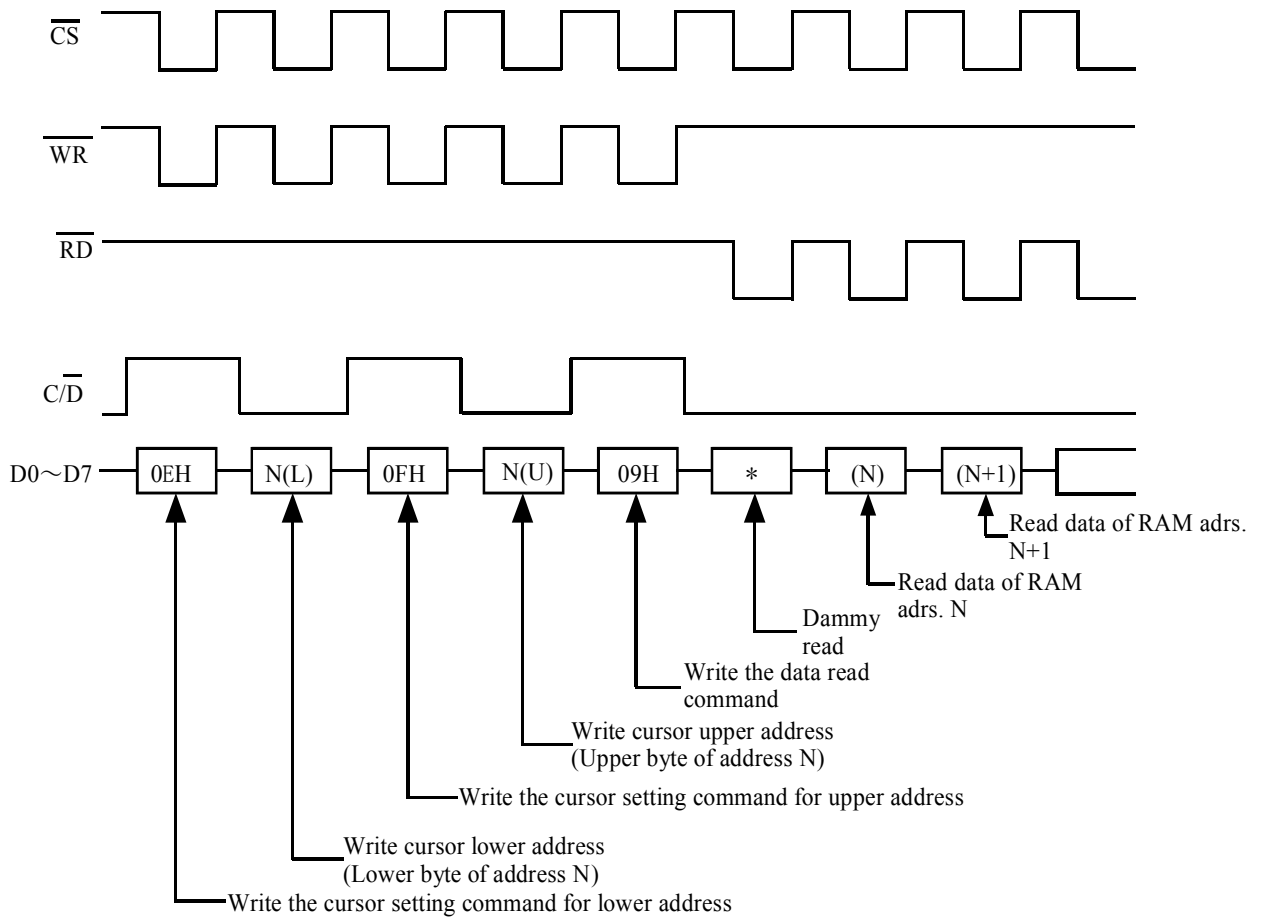

9.6 Setting of Display Start Address

Command(C/D= $\overline{1}$)					Setting Data(C/D= $\overline{0}$)								Function
D4	D3	D2	D1	D0	D7	D6	D5	D4	D3	D2	D1	D0	
0	1	0	1	0	A7	A6	A5	A4	A3	A2	A1	A0	Lower byte of Screen#1 display address.
0	1	0	1	1	X	X	X	A12	A11	A10	A9	A8	Upper byte of Screen#1 display address.
0	1	1	0	0	A7	A6	A5	A4	A3	A2	A1	A0	Lower byte of Screen#2 display address.
0	1	1	0	1	X	X	X	A12	A11	A10	A9	A8	Upper byte of Screen#2 display address.

After writing of appropriate command from above, the display start address will be written into the address register.

The display start address is always pointed to the RAM address where is stored the data will be displayed at most left and the top line of the screen. Using with these commands, page rolling, one-line-left/right scrolling (one dot unit) at graphics display or one-line-upper/lower scrolling(8 dot unit) at character display are available.

Since FRP signal is triggered at each frame of display refreshing, the most smooth scrolling can be achieved by synchronizing of changing of the display address with the FRP.

CAUTION: It is necessary to set lower address first, and set upper address.

9.7 Cursor Address Set

Command(C/D= $\overline{1}$)					Setting Data(C/D= $\overline{0}$)								Function
D4	D3	D2	D1	D0	D7	D6	D5	D4	D3	D2	D1	D0	
0	1	1	1	0	A7	A6	A5	A4	A3	A2	A1	A0	Set lower byte of cursor address.
0	1	1	1	1	X	X	X	A12	A11	A10	A9	A8	Set upper byte of cursor address.

The cursor address is written into cursor address counter with this command.

The cursor address is a address to read/write RAM data.

It is necessary to set cursor address before execution of data write command (08H) or data read command (09H).

The cursor address is divided into the 2 portions as upper (5 bits) and lower (8 bits) address and there are following restrictions.

Desire to change(set) the address both upper and lower	Firstly, set the lower and then upper address.
Desire to change(set) the lower address only	Upper address set is required after setting of lower address.
Desire to change(set) the upper address only	Set the upper address. Not need to change (set) the lower address.

9.8 Screen Luminance Control.

Command(C/D= $\overline{1}$)					Function
D4	D3	D2	D1	D0	
1	1	0	0	0	Set brightness 100.0%
1	1	0	0	1	Set brightness 87.5%
1	1	0	1	0	Set brightness 75.0%
1	1	0	1	1	Set brightness 62.5%

Screen Luminance can be varied by above command.

At power on , Screen Luminance is set to 100%.

10. Blanking

Display will be turned off without changing any other register setting or modes, when BL is “0” level. There are no change in the RAM during blanking, previous display will be recovered by BL=’1”.

11.Address Map

11.1 Graphic Display

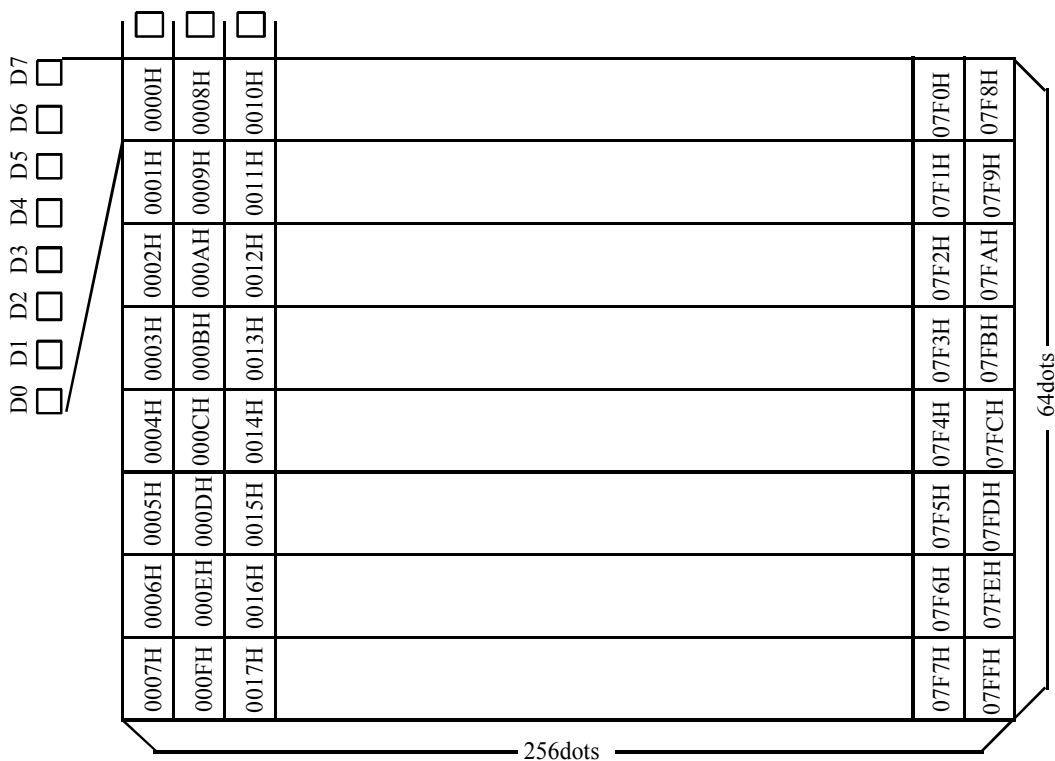

< Above map shows in the case of 0000H of start address. >

11.2 Character Display

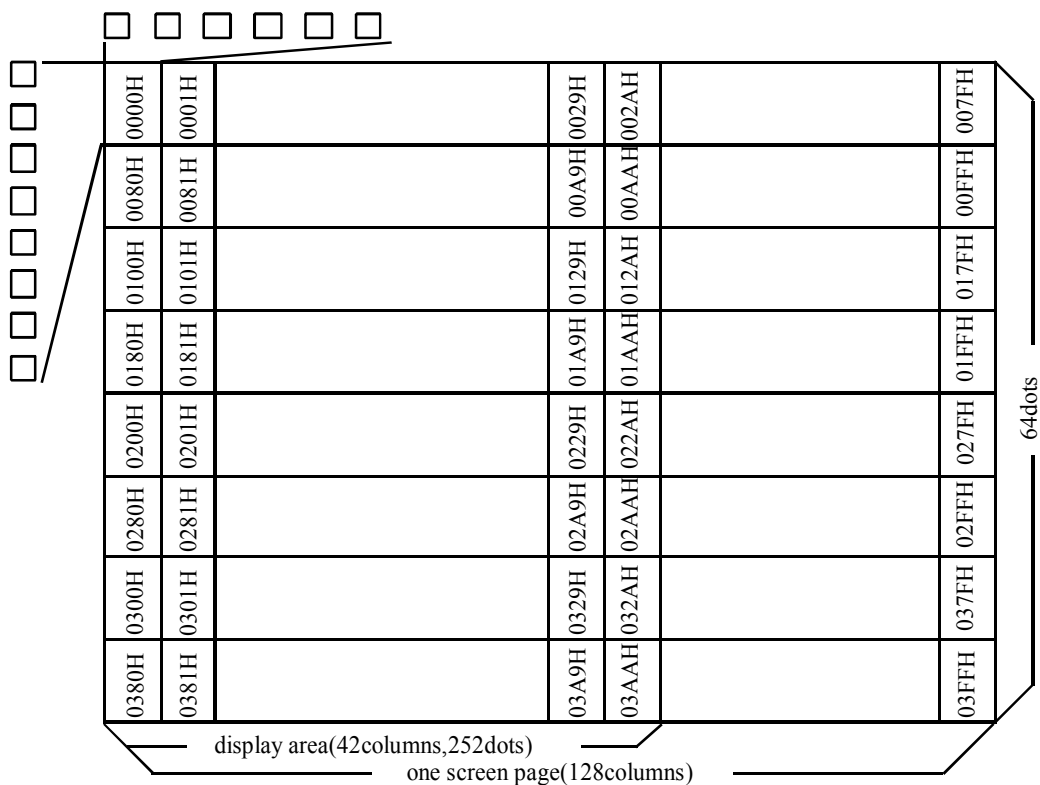

< Above map shows in the case of 0000H of start address. >

12. Test Mode

Test Mode is set by keeping $\overline{\text{TEST}}$ low for more than 100mS at power on or initialize.
 During Test Mode, all dots are on automatically, and no any data are acceptable.

13. Interfacing

$\overline{\text{CS}}$	$\overline{\text{WR}}$	$\overline{\text{RD}}$	C/D	$\overline{\text{BL}}$	Function
0	0→1	1	1	-	Command write(Host system→ Module)
0	0→1	1	0	-	Data write (Display pattern, Address) (Host system → Module)
0	1	0	1	-
0	1	0	0	-	Display data read(Host system ← Module)
-	-	-	-	0	Display Blanking

Since data execution time of the module is 2us (Max.), there are no BUSY or READY output.
 Therefore more than 2us time period is required between module access.

[An example of interfacing]

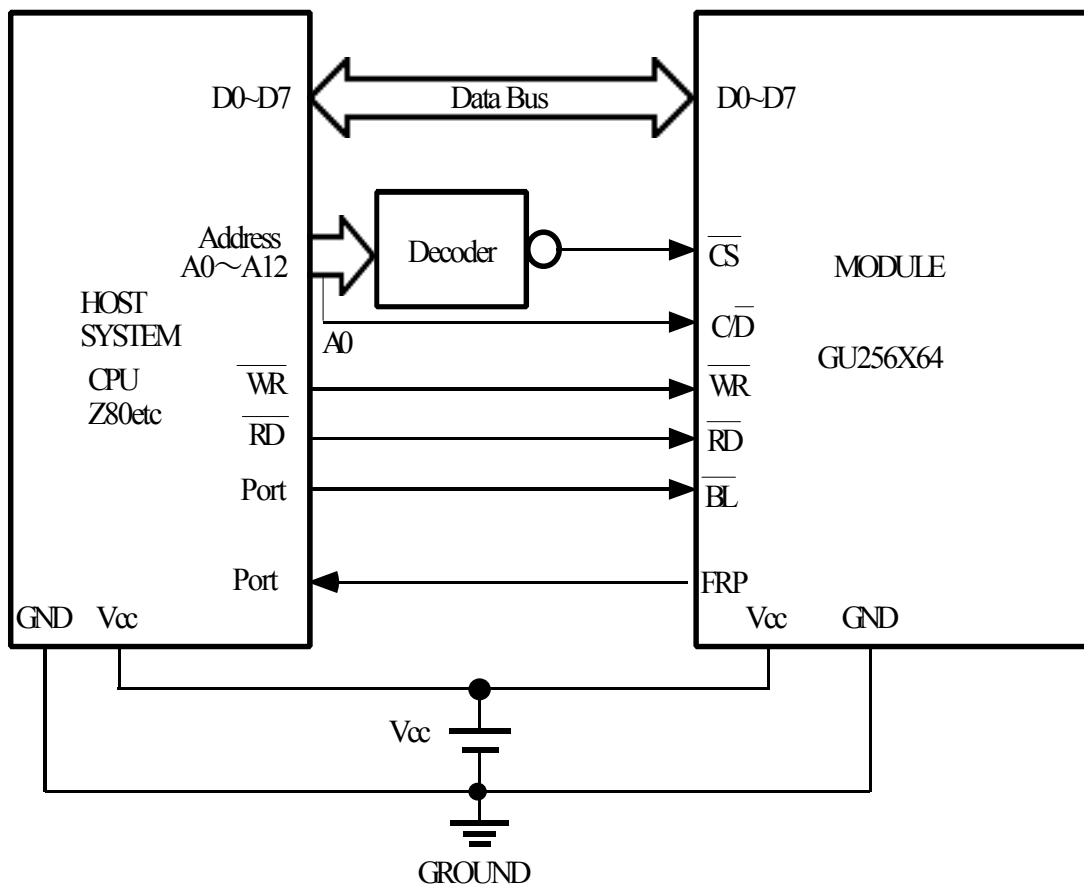

CAUTION : Because of adoption of C-MOS input logic in the module, shorter than 30cm cable length between a host system and the module is kindly suggested for free from permanent damages caused by noise.

14. Timing Chart

14.1 Write Operation

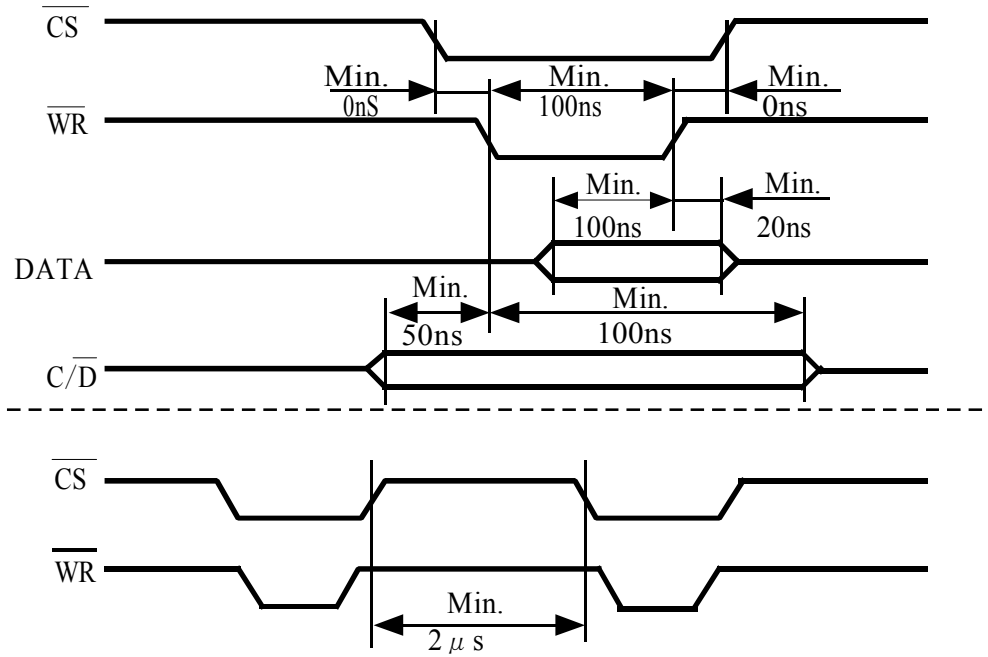

14.2 Read Operation

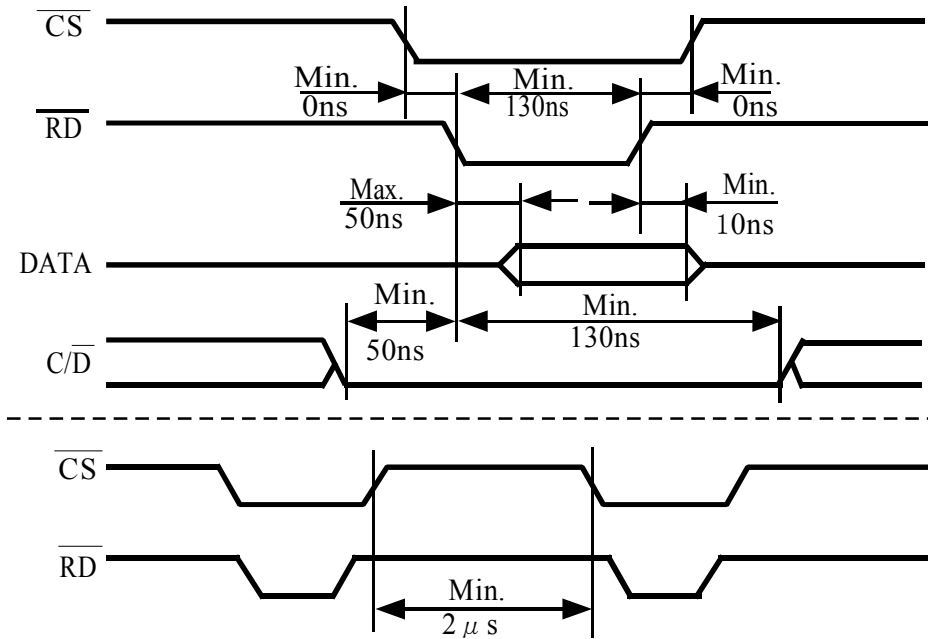

14.3 Output Timing of FRP (Output)

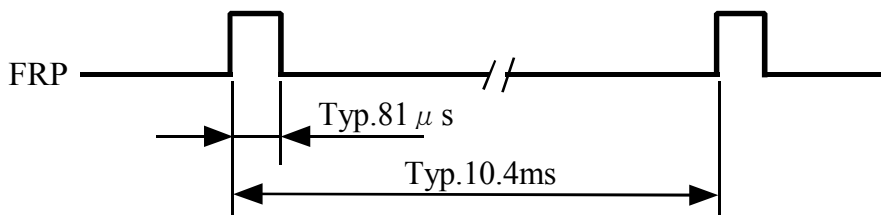

15.Pin Assignment

15.1 Signal Connector

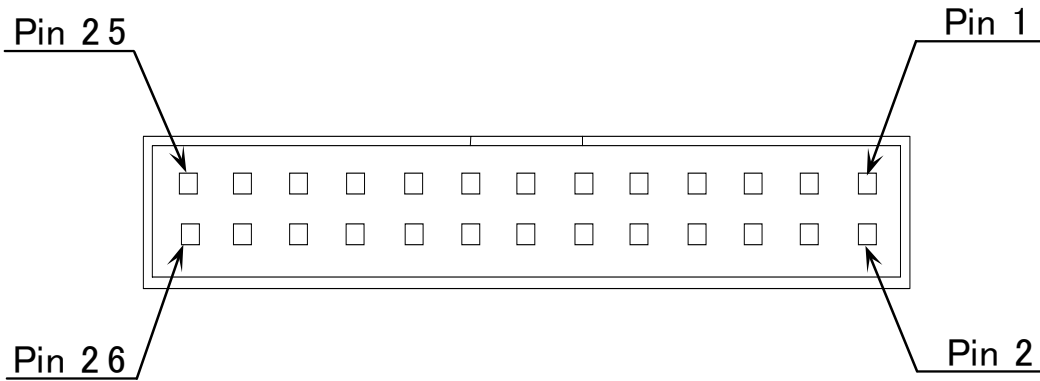

Pin No.	Description	Pin No.	Description
1	D7	2	GND
3	D6	4	GND
5	D5	6	GND
7	D4	8	GND
9	D3	10	GND
11	D2	12	GND
13	D1	14	GND
15	D0	16	GND
17	$\overline{\text{WR}}$	18	GND
19	$\overline{\text{C/D}}$	20	GND
21	$\overline{\text{RD}}$	22	GND
23	$\overline{\text{CS}}$	24	GND
25	FRP	26	$\overline{\text{BL}}$

15.2 Power Connector

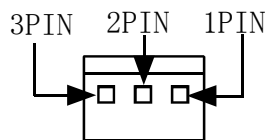

Pin No.	Description
1	+5V(Vcc)
2	$\overline{\text{TEST}}$
3	GND

16. Outline Dimension

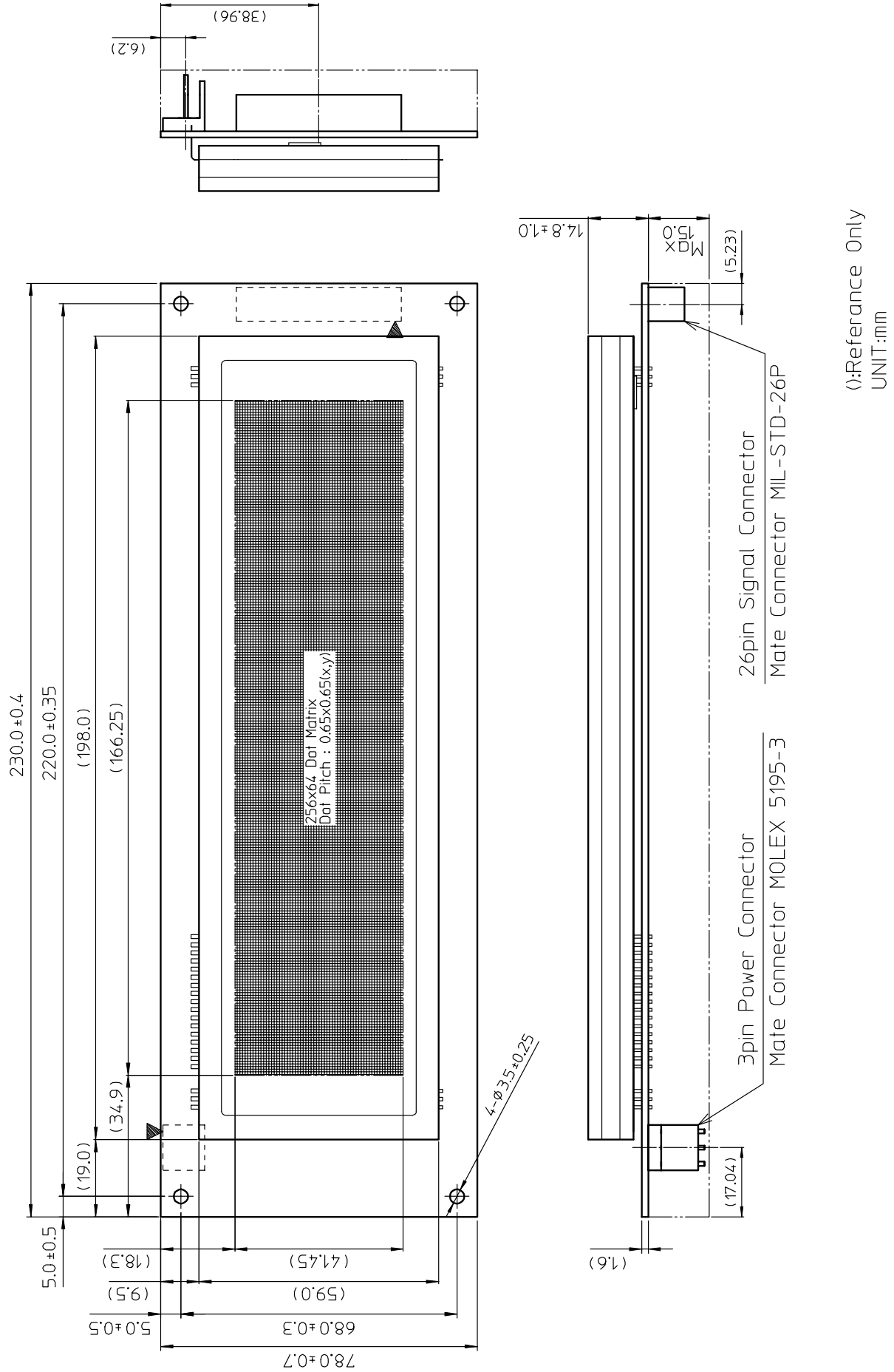

Notice for the Cautious Handling VFD Modules

Handling and Usage Precautions:

Please carefully follow the appropriate product application notes for proper usage, safety handling, and operation standards for maximum performance.

[VFD tubes are made of glass]

- Because the edges of the VFD glass-envelop are not smooth, it is necessary to handle carefully to avoid injuries to your hands
- Please avoid breaking the VFD glass-envelop to prevent injury from sharp glass particles.
- The tip of the exhaust pipe is fragile so avoid shock from impact.
- It is recommended to allow sufficient open space surrounding the exhaust pipe to avoid possible damage.
- Please design the PCB for the VFD-module within 0.3 mm warping tolerance to avoid any forces that may damage the display due to PCB distortion causing a breakdown of the electrical circuit leading to VFD failure.

[High voltage]

- Avoid touching conductive electrical parts, because the VFD-module uses high voltage exceeding 30~100 volts.
- Even when electric power is turned off, it may take more than one minute for the electrical current to discharge.

[Cable connection]

- Do not unplug the power and/or data cables of VFD-modules during operating condition because unrecoverable damage may result.
- Sending input signals to the VFD-module during a power off condition sometimes causes I/O port damage.
- It is recommended to use a 30 cm or shorter signal cable to prevent functional failures.

[Electrostatic charge]

- VFD-modules need electrostatic free packaging and protection from electrostatic charges during handling and usage.

[Structure]

- During operation, VFD and VFD-modules generate heat. Please consider sufficient heat radiation dissipation using heat sink solutions.
- We prefer to use UL grade materials or components in conjunction with VFD-modules.
- Wrap and twist motion causes stress and may break VFDs & VFD modules. Please adhere to allowances within 0.3mm at the point of attachment.

[Power]

- Apply regulated power to the VFD-module within specified voltages to protect from failures.
- Because some VFD-modules may consume in rush current equal to twice the typical current at power-on timing, we recommend using a sufficient power capability and quick starting of the power regulator.
- VFD-module needs a specified voltage at the point of connection. Please use an adequate power cable to avoid a decrease in voltage. We also recommend inserting a power fuse for extra protection.

[Operating consideration]

- Illuminating phosphor will decrease in brightness during extended operation. If a fixed pattern illuminates for an extended period,(several hours), the phosphor efficiency will decrease compared to the non operating phosphor causing a non uniform brightness among pixels. Please consider programming the display patterns to use all phosphor segments evenly. Scrolling may be a consideration for a period of time to refresh the phosphor condition and improve even illumination to the pixels.
- We recommend using a signal cable 30cm or less to avoid some possible disturbances to the signal.

[Storage and operating environment]

- Please use VFD-modules under the recommended specified environmental conditions. Salty, sulfur and dusty environments may damage the VFD-module even during storage.

[Discard]

- Some VFDs contain a small amount of cadmium in the phosphor and lead in the solder. When discarding VFDs or VFD-modules, please adhere to governmental related laws or regulations.

[Others]

- Although the VFD-module is designed to be protected from electrical noise, please plan your circuitry to exclude as much noise as possible.
- Do not reconstruct or repair the VFD-module without our authorization. We cannot assure the quality or reliability of unauthorized reconstructed VFD-modules.

Notice:

- We do not authorize the use of any patents that may be inherent in these specifications.
- Neither whole nor partial copying of these specifications are permitted without our approval.
If necessary , please ask for assistance from our sales consultant.
- This product is not designed for military, aerospace, medical or other life-critical applications. If you choose to use this product for these applications, please ask us for prior consultation or we cannot take responsibility for problems that may occur.

Mouser Electronics

Authorized Distributor

Click to View Pricing, Inventory, Delivery & Lifecycle Information:

[Noritake:](#)

[GU256X64F-9900](#) [GU256X64-372](#)